

AXLE SUSPENSION LOCKS LH

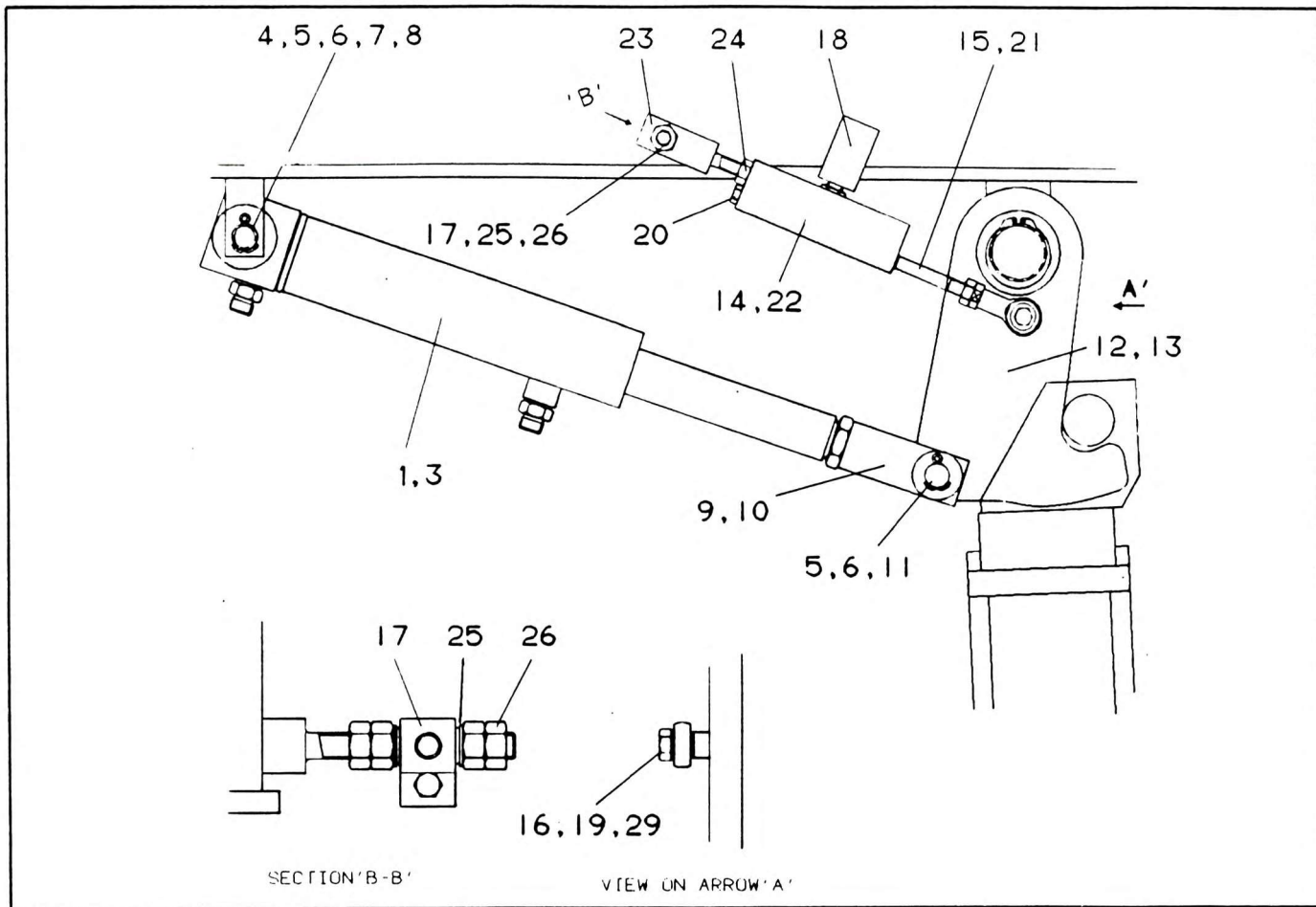

NO.	PART NO.	QTY.	DESCRIPTION	NO.	PART NO.	QTY.	DESCRIPTION
1 +	6-372-004389	1	Cylinder 36 Rod 170 Stroke	23	7-661-190003	1	Nut M10
3	7-447-060601	2	Adaptor	24	6-689-990365	1	Pin Block
4	6-689-990338	1	Pin Suspension Lock	25	7-951-190014	2	Washer M10
5	7-690-102010	2	3/16" x 1 1/4" Long Split Pin	26	7-661-210003	4	Nut
6	7066619	2	Washer Plain 20m Dia.	29	7-126-191553	1	Screw M10 x 40 Long
7	7069601	1	Nut M20	+ See further breakdown in this group			
8	7067310	1	Washer Spring M20				
9	8867620	1	Clevis				
10	7069703	1	Nut Lock M24				
11	292566	1	Pin				
12	6-966-990275	1	Link Weld				
13	7082123	1	Circlip Ext. 45 Nom. Dia.				
14	6-086-990307	1	Block - Switch				
15	6-768-990159	1	Rod - Axle Stop				
16	6-910-990928	1	Spacer				
17	6-910-990963	1	Spacer				
18	7-872-990273	1	Limit Switch				
19	7-069-990089	1	Bearing Spherical				
20	13149	1	Plug Drain 1/4"				
21	7-661-190003	1	Nut M10				
22	7-753-990031	1	Wiper Ring				